

Quick Installation Guide

NFO Sinus Optimal with Safe Torque Off

1 Mechanical installation

- ⚠ When unpacking the inverter, carefully inspect the product and make sure it has not been damaged during transportation. An inverter with cracks, dents or other visual damage shall not be installed.
- ⚠ The inverter must not be installed so that outlet air from another inverter or other equipment blows directly into the inverter air intake. A minimum of 80 mm clearance must be kept above and below the inverter.
- ⚠ All terminals are accessed by opening the plastic cover. To be able to use the snap-and-hold-open functionality of the cover, a free space of 200 mm is required above the inverter.
- ⚠ During installation it is important that no foreign objects, such as cable strands or screws, fall into the inverter as a short circuit may occur. Drilling in chassis or cover is not allowed.
- ⚠ After installation, make sure all grommets at the cable entries are mounted and that the cover is closed and secured with its screws to avoid access to dangerous voltages.

1.1 Mounting

- Unscrew the two lower captive screws and loosen the inverter from the backplate.
- Fasten backplate to a vertical surface using four screws. Make sure that the top mounting screws are sufficiently strong to hold the entire weight of the inverter.
- Place the inverter on the backplate by mating the chassis cut-out to the backplate hooks. Tighten the lower captive screws on both sides.

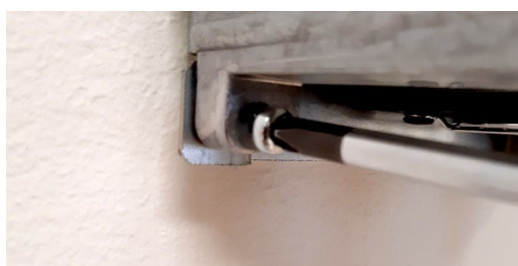
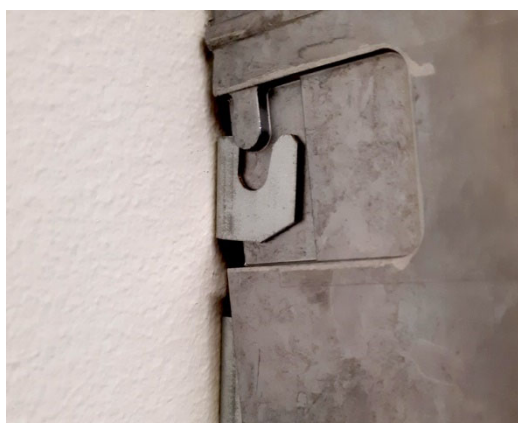

2 Electrical installation

- Connect **mains power** to terminals **L1, L2, L3** and **PE**.
- Connect **motor cable** to terminals **U, V, W** and **PE** using standard unshielded cable.
- Connect **Safe Torque Off** terminals (STO1P-STO1N and STO2P-STO2N) to external emergency stop switch, or strap terminals internally if Safe Torque Off is not used.

⚠ Never install contactors or switches between the inverter (terminals U, V and W) and the motor that intentionally or unintentionally may be used to disconnect the motor from inverter output.

⚠ A motor safety switch can be mounted between the inverter (terminals U, V and W) and the motor, but it must only be operated when the motor is not running.

⚠ First time powered up, the installer must select application, enter motor name plate data, and perform a motor tuning (see next section).

- Connect/install the necessary low voltage signalling that is required for your application, e.g. a run signal for start/stop, analog input for setpoint, communication, etc.

⚠ Make sure run signal is not activated until installer has completed the setup of the inverter.

⚠ Make sure the low voltage signal wires have sufficient isolation when passing nearby power cables.

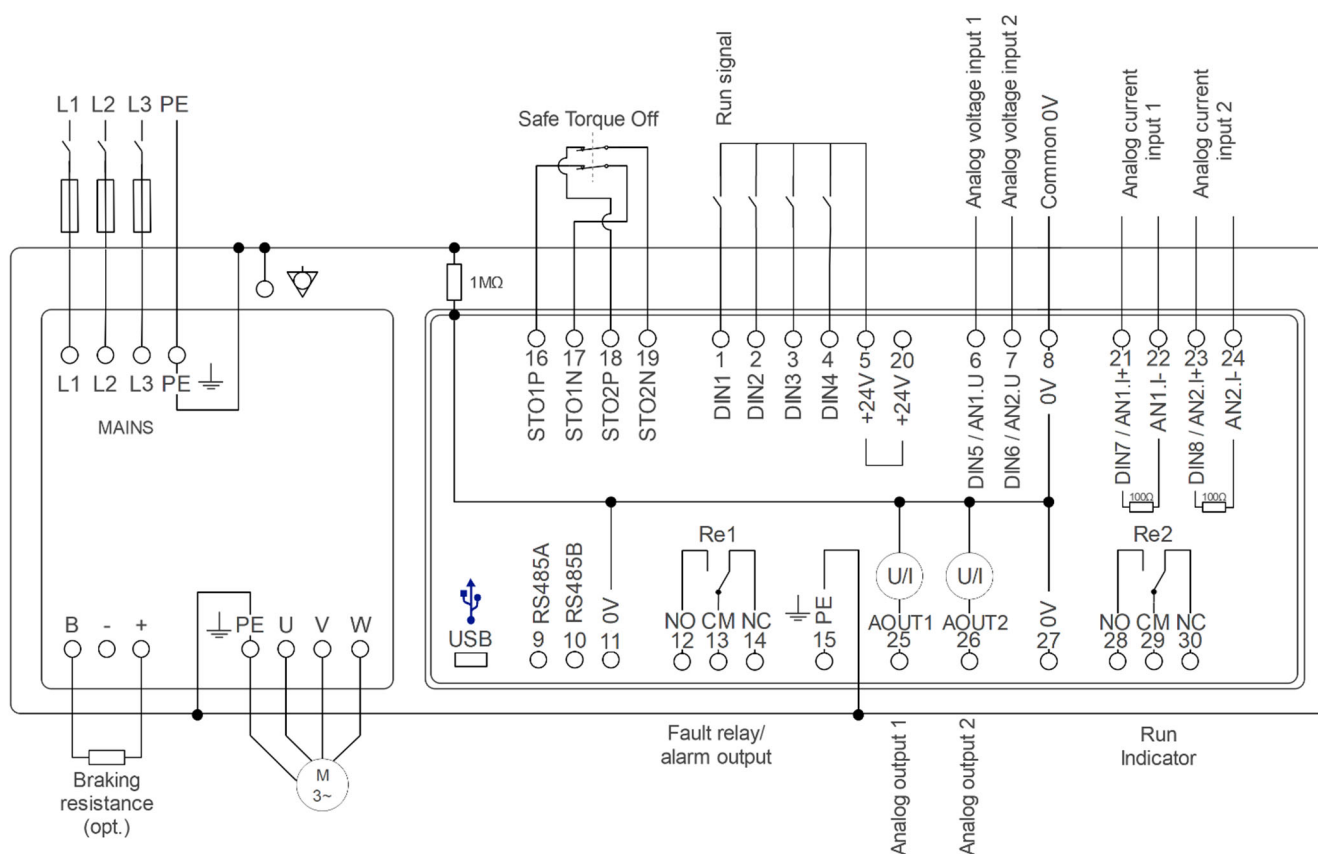

Fig 1. Default setup

3 Initial setup and tuning

3.1 Select application

- First time powered up after installation, or after performing a factory reset of parameters, the installer will be prompted to select application type for the inverter.
- The purpose of selecting application is to preset acceleration and deceleration ramps to a value suitable for the application in question.
- Please note that the preset values are a merely suggested general values. Depending on other operating conditions, the installer may have to further adjust the accel/decel ramps.

Application	Description
Pump	Set acceleration and deceleration ramps suitable for general pump applications
Ventilation / other	Set acceleration and deceleration ramps suitable for ventilation fan applications
OEM vacuum pump	To be used <u>only</u> with OEM vacuum pump application

3.2 Enter motor data and perform tuning

- First time powered up after installation, or after performing a factory reset of parameters, the installer must enter the motor name plate data. The motor data is entered in the parameter group Motor and consists of P-nom, U-nom, f-nom, N-nom, I-nom and $\cos \varphi$. The data can be read from the motor name plate.
- After motor data is entered, the installer must perform a motor tuning during which the inverter measures and calculates the electrical properties of the motor. The tuning command is located in parameter group Motor, adjacent to the motor data values. Select 'Full' tuning for most thorough measurement.
- Until a correct tuning is performed, the inverter will toggle the status message '**Not Tuned**' on the display.
- Please refer to the Operating and Installation Manual for a complete description of the tuning commands.

3.3 Check rotation direction

- After selecting application, entering motor data and performed tuning, it may be necessary to check/verify correct rotation direction of the rotor.
- This can be done by starting the motor at a low speed in manual mode.
- Manual mode is selected when lower right corner of display reads '**Manual**'. Pressing the '**MAN / AUTO**' button toggles between manual and auto mode.
- Pressing '**START**' button in manual mode starts the motor.
- Direction of rotation can be changed by changing the parameter '**Phase order**' in parameter group '**Run**'. The motor must be stopped when changing this parameter.
- Default setpoint frequency in manual mode is 10.0 Hz. If necessary, increment or decrement setpoint using the arrow up/down buttons.
- When ready, press '**STOP**' and then press the '**MAN / AUTO**' button to select '**Auto**' mode. The inverter is now ready to start operating according to the connected control signals.

Keyboard and menu summary



Button	Function
	Enter into parameter or parameter-group. Save parameter.
	Enter/toggle between normal screen and setup menu tree. Leave parameter, parameter-group or leave parameter unsaved.
	Toggle Operating mode between <i>Manual</i> and <i>Auto</i> . Starts motor in <i>Auto</i> mode if Run signal active.
	Starts motor in <i>Manual</i> mode.
	Stops motor in all modes. NOTE: A bus master may start motor at any time
	Increase parameter when changing. Moves between parameter-groups or parameters.
	Decrease parameter when changing. Moves between parameter-groups or parameters.

Motor	Ramp	Run	Control	Freq.	Speed	PI-reg	Output	Comm.	Status	Temp.	Display	Count.	Version	Error
P-Nom	Accel Time	Phase Order	Control Mode	Op Mode	Op Mode	Op Mode	Relay 1 Mode	RS485 bustype	Urms	Motor Temp	Display Par 1	Operate Time	COP Version	Error Log
U-Nom	Decel Time	Stop Mode	Auto Start	FixFrq1	FixSpd1	FixReg1	Relay 1 Freq	RS485 addr	I-rms	Power Module	Display Par 2	Run Time	DSP Version	Restart Delay
f-Nom	Ramp Brkpoint	Energy Save	An Input 1 Type	FixFrq2	FixSpd2	FixReg2	Relay 2 Mode	RS485 baud	Pout	COP Temp	Display Par 3	Brake Time	GUI Version	Reset Time
N-Nom	Alt Accel Time	Pwr On Delay	An Input 2 Type	FixFrq3	FixSpd3	FixReg3	Relay 2 Freq	RS485 char	PF	Heat Sink 1	Bklight Level	Cur Lim Time	Prod Date	AC Fail
I-Nom	Alt Decel Time	Run Delay	DIN2 Function	FixFrq4	FixSpd4	FixReg4	AnOut 1 Mode	RS485 timeout	DC Link	Heat Sink 2	Bklight Timeout	DC Low Time	Serial Number	Temp Hi
cos φ		Stop Delay	DIN3 Function	FixFrq5	FixSpd5	FixReg5	AnOut 1 Type	RS485 autostop	Brake Chop	Heat Sink 3	Menu readonly	Start Count		PTC Temp
Tuning		DC Brake	DIN4 Function	FixFrq6	FixSpd6	FixReg6	AnOut 1 Max	RS485 failsafe	Stator Freq	Heat Sink 4	Show freq in %	Alarm Count		Over load
R-stator		Kp Speed	DIN5 Function	FixFrq7	FixSpd7	FixReg7	AnOut 2 Mode	USB bustype	Rotor Freq	Fan 1 Volt		STO Run Cnt		Ain Fail
R-rotor		Ti Speed	DIN6 Function	An Min Freq	An Min Speed	Setpoint Min Val	AnOut 2 Type	USB addr	Control Freq	Fan 2 Volt		STO Stby Cnt		DC Low
L-main		Sleep Freq	DIN7 Function	An Max Freq	An Max Speed	Setpoint Max Val	AnOut 2 Max	USB timeout	Rotor Speed	Fan 3 Volt		SET Err Cnt		DC High
Sigma		Bypass Freq	DIN8 Function			Actual Min Val	Analog 1 Out	USB autostop	Control Speed	Fan 4 Volt		Firemd Count		GND Fail
I-magn		Bypass Bandw	DIN1-4 Logic			Actual Max Val	Analog 2 Out	ABCC interface	Actual Torque	EXT 24V		Output Energy		Short Circuit
I-limit		Boost Time	Fire Mod Setpoint			Setpoint Min Lim		ABCC bustype	Control Torque	USB 5V		Total Energy		Imagn Low
Pole Count		Boost Level	Fire Mod Type			Setpoint Max Lim		ABCC addr	Actual Reg					Current Low
T-nom			Limit ManSetp			Reg Amp		ABCC timeout	Setpoint Reg					Current High
Tuned status						Reg Kp		ABCC autostop	AnIn1 U					Current Limit
						Reg Ti		Auto Reset	AnIn1 I					Run Fail
						MinFreq			AnIn2 U					
						MaxFreq			AnIn2 I					
						Reg Unit			Keybrd					
						Off Limit			Terminal					
						On Limit			Function					